

SECTION VIEW

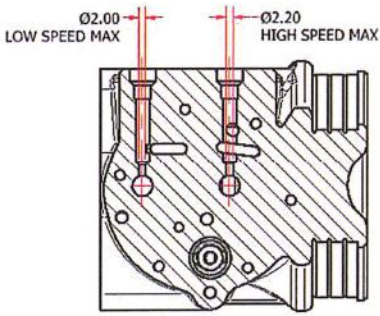

SECTION A-A
SCALE 1 : 1

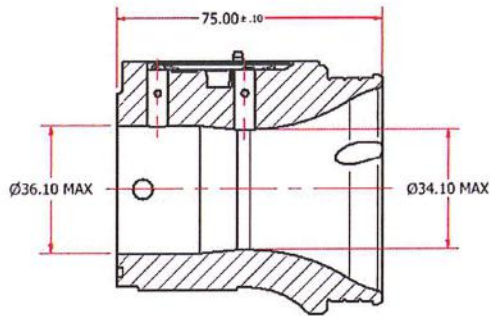

SECTION B-B
SCALE 1 : 1

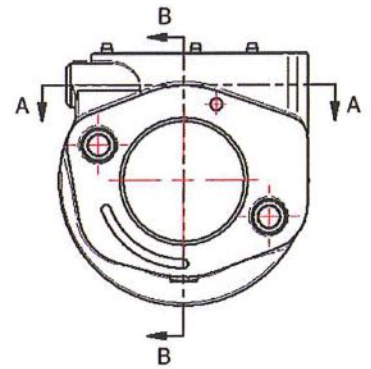

FLANGE SIDE

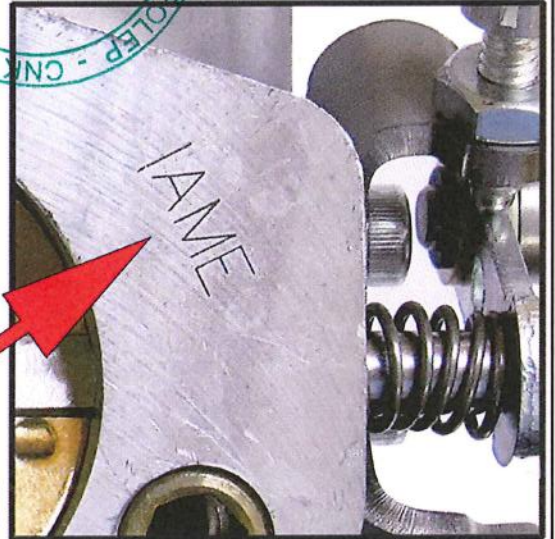
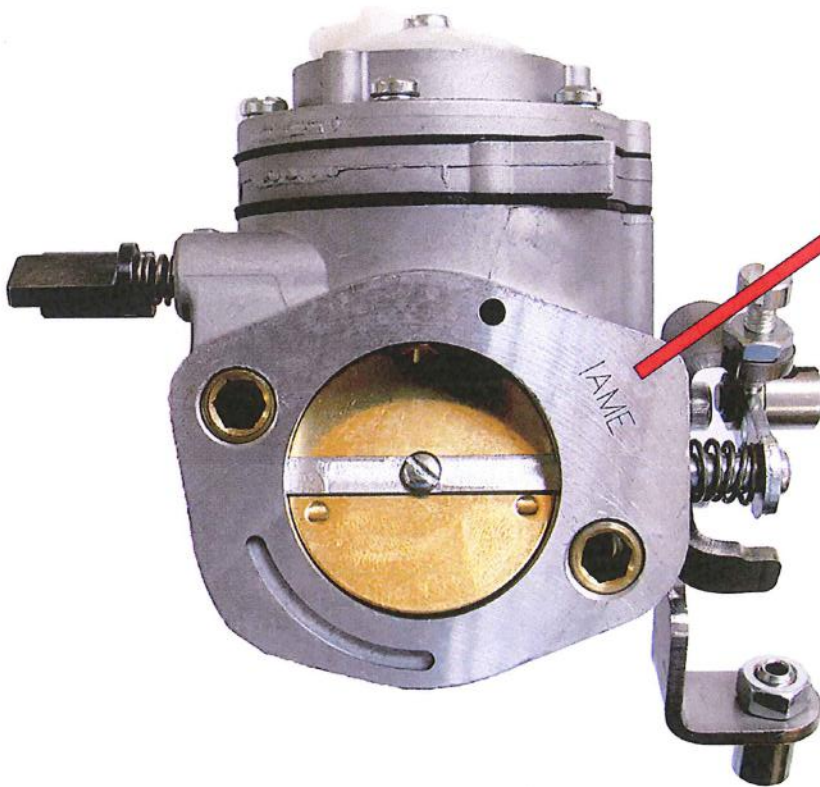

CARBURETTOR DESCRIPTION AND SKETCH OF PARTS

HB-10A

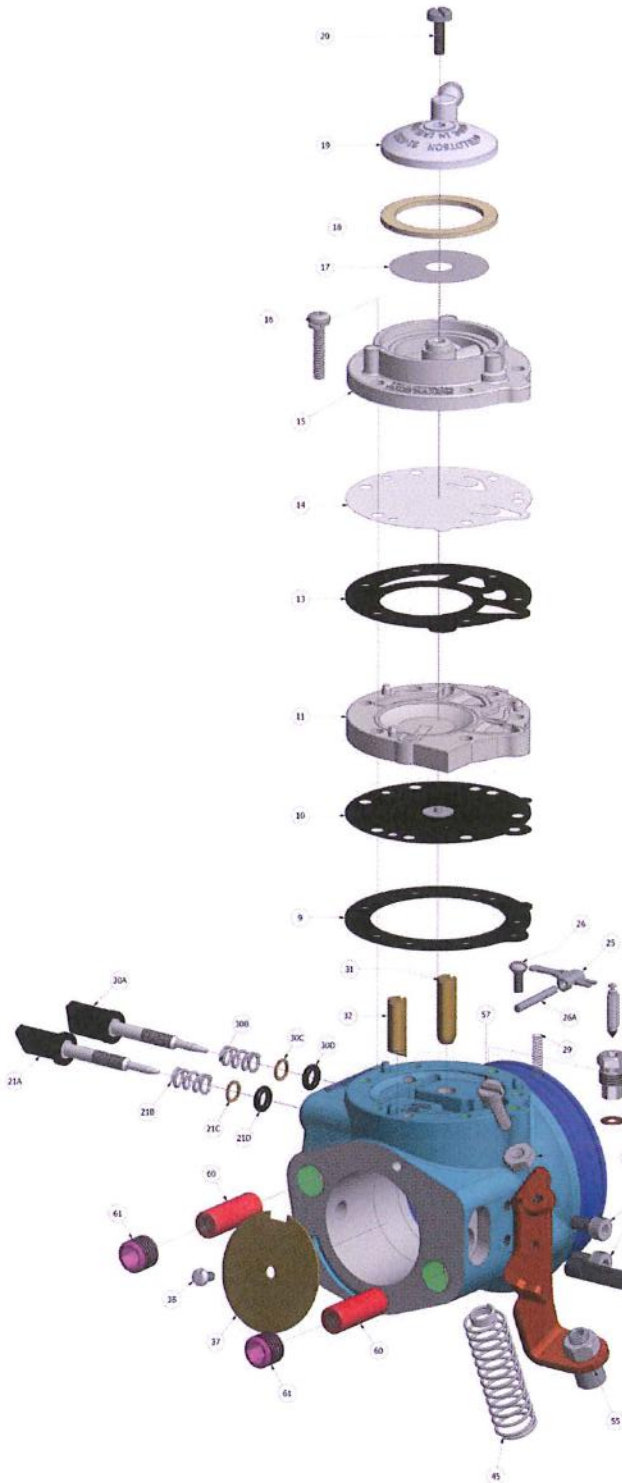

ITEM	PART NO.	DESCRIPTION	QTY
9	+ * 16-B408	DIAPHRAGM GASKET	1
10	+ * 237-698	DIAPHRAGM	1
11	91A-275	DIAPHRAGM COVER	1
13	+ * 16-B392	FUEL PUMP GASKET	1
14	+ * 237-223	FUEL PUMP DIAPHRAGM	1
15	141-89	FUEL PUMP BODY	1
16	15C-51	FUEL PUMP BODY SCREW	6
17	95 - 170	FUEL STRAINER SCREEN	1
18	+ * 16-B205	FUEL STRAINER COVER GASKET	1
19	91-A251	FUEL STRAINER COVER	1
20	15-B313	FUEL STRAINER COVER RETAINING SCREW	1
21A	43-1029	IDLE MIXTURE SCREW	1
21B	24-B449	IDLE MIXTURE SCREW SPRING	1
21C	78A-256	IDLE MIXTURE SCREW WASHER	1
21D	44-361	IDLE MIXTURE SCREW PACKING	1
25	* 155A-27	INLET CONTROL LEVER	1
26	15-B329	FULCRUM LEVER SCREW	1
26A	32-79	FULCRUM LEVER PIN	1
27	* 233-717P	INLET NEEDLE & SEAT SET	1
28	16-B199	INLET SEAT GASKET	1
29	24-B299	INLET TENSION SPRING	1
30A	43-1030	HIGH SPEED MIXTURE SCREW	1
30B	24B-449	HIGH SPEED MIXTURE SCREW SPRING	1
30C	78A256	HIGH SPEED MIXTURE SCREW WASHER	1
31	363-332	HIGH SPEED NOZZLE	1
32	363-331	LOW SPEED NOZZLE	1
30D	44-361	HIGH SPEED MIXTURE SCREW PACKING	1
33	29-224	THROTTLE SHAFT CLIP	1
35	15-C19	THROTTLE SHAFT CLIP RETAINING SCREW	1
36	24-B381	THROTTLE RETURN SPRING	1
37	14-A121	THROTTLE SHUTTER	1
38	15-C20	THROTTLE SHUTTER SCREW	1
42	13-B236	THROTTLE SHAFT	1
43	12-1220	THROTTLE LEVER ASSEMBLY	1
44	15-C52	THROTTLE LEVER RETAINING SCREW	1
45	24-C334	SECONDARY THROTTLE RETURN SPRING	1
55	136-A62	CABLE BRACKET	1
56	15-C67	CABLE BRACKET RETAINING SCREW	2
57	15-C9	LIMITER SCREW	2
58	81-383	LIMITER NUT	2
60	81-377	CARBURETTOR MOUNTING NUT	2
61	81-382	MOUNTING NUT CLOSURE	2
RK-1HB		REPAIR KIT	
DG-1HB		DIAPHRAGM & GASKET (STANDARD)	
233-717P		INLET NEEDLE & SEAT SET	
* INDICATES CONTENTS OF REPAIR KIT			
* + INDICATES CONTENTS OF DIAPHRAGM & GASKET SET			



Clash Industrial Estate - Tralee - Ireland
www.tillotson-racing.com

PARTS OF CARBURETTOR

REF.9 - P. N°16-B408

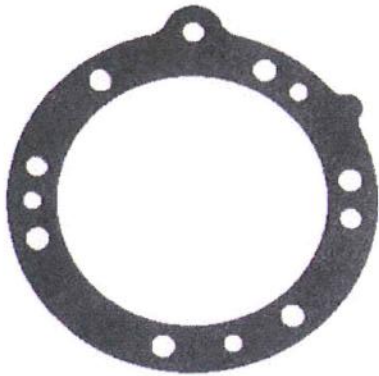

Thickness = 1.00 ± 0.1 mm

PUMP DIAPHRAGM GASKET
REF.13 - P. N° 16-B392



Thickness = 0.8 ± 0.1 mm

REF.10 - P. N°237-698
DIAPHRAGM

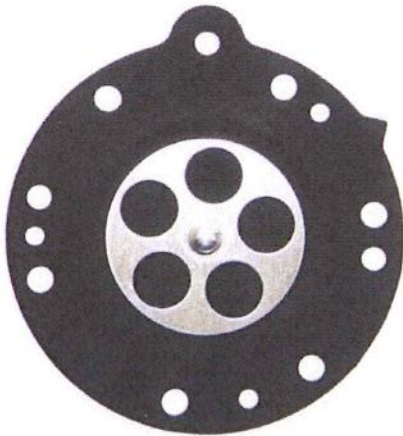

Thickness = 0.13 ± 0.07 mm

REF.14 - P. N°237-223
PUMP DIAPHRAGM



Thickness = 0.075 ± 0.07 mm

REF.11 - P. N° 91-1031
DIAPHRAGM COVER



Thickness = 6.75 ± 0.15 mm

REF.15 - P. N° 141-89
PUMP COVER



Thickness = 12.5 ± 0.15 mm



